

Report Number: QIP-ASI104287

Audit Date : 29-April-2010
Expiry Date : 28-April-2011

This report is issued by Focus Technology Co., Ltd (Made-in-China.com) and the supervising inspectorate (SGS-CSTC Standards Technical Services Co., Ltd.) to confirm that:

Company Name : Jiangyan Jiacheng Plastic Goods Factory
 姜堰市嘉诚塑料制品厂
Showroom : <http://jyjiacheng.en.made-in-china.com/>
Address : Meiwang Village, Zhangdian Town, Jiangyan, Taizhou, Jiangsu, China
Product : Plastic Bag, Zip Lock Bag

has been on site audited for the Following Scope of Activity

1. General Information
2. Foreign Trade Capacity
3. Production Capacity & Quality Control
4. Photos



General Comments:

Jiangyan Jiacheng Plastic Goods Factory is a combined unit with 30 employees; it was established in 2007, located in Meiwang Village, Zhangdian Town, Jiangyan, Taizhou City. The workshops occupy an area of around 1,000 square meters, and the annual production output was 600 Tons in last year. Jiangyan Jiacheng company has successful foreign trading experience in Russia, Europe and Middle east, their target of foreign trade revenue was around RMB 7,000,000 in year 2010.



Sign for and on behalf of
 SGS-CSTC Standards Technical Services Co., Ltd.

This document is issued by the Company under its General Conditions of Service accessible at http://www.sgs.com/terms_and_conditions.htm. Attention is drawn to the limitation of liability, indemnification and jurisdiction issues defined therein. Any holder of this document is advised that information contained hereon is solely limited to visual examination of the safely and readily accessible portions of the consignment and reflects the Company's findings at the time of its intervention only and within the limits of Client's instructions, if any. The Company's sole responsibility is to its Client and this document does not exonerate parties to a transaction from exercising all their rights and obligations under the transaction documents. Any unauthorized alteration, forgery or falsification of the content or appearance of this document is unlawful and offenders may be prosecuted to the fullest extent of the law.

Attention: To check the authenticity of testing /inspection report & certificate, please contact us at telephone: (86-755)83071443, or email: CN.Doccheck@sgs.com

Page No.: 1 of 10

SUPPLIER ASSESSMENT REPORT

Audited Company	Jiangyan Jiacheng Plastic Goods Factory 姜堰市嘉诚塑料制品厂
Audited Site:	Meiwang Village, Zhangdian Town, Jiangyan, Taizhou, Jiangsu, China
Representative of Audited Company:	Ms. Cherry Hang / Sales Manager

Consigner of Assessment	Made-in-China.com		
Audit Type	<input checked="" type="checkbox"/> Initial Audit <input type="checkbox"/> Follow-up Audit <input type="checkbox"/> Re-audit		
Valid Date	From 29 Apr., 2010 to 28 Apr., 2011	Verify Report	as.cn@sgs.com
Auditor Name	Kain Qian	Reviewed by	Roger Wang

CONTENTS

- Part A: General Information**
 - Section 1: Company Overview
 - Section 2: Human Resources
- Part B: Foreign Trade Capacity**
 - Section 1: Export Overall Situation
 - Section 2: Export Business Capacity
 - Section 3: Supplier Management
 - Section 4: After Service Capacity
- Part C: Product Research & Development Capacity**
 - Section 1: Product Research & Development Capacity
- Part D: Quality Management System and Product Certification**
 - Section 1: Quality Management System(s) and Product Certification
- Part E: Production Capacity & Quality Control**
 - Section 1: Production Capacity Section
 - Section 2: Production Process Control
 - Section 3: Company Development / Expansion Plan
- Part F: Financial Position**
 - Section 1: Financial Data
 - Section 2: Key Performance Indications
 - Section 3: Banking
 - Section 4: Product Insurance
- Part G: Working Environment & Energy Saving**
 - Section 1: Working Environment
 - Section 2: Energy Savings and Emission Reduction
- Part H: Photos**
 - Section 1 : Photos of Documents
 - Section 2: Photos of Company

This document is issued by the Company under its General Conditions of Service accessible at http://www.sgs.com/terms_and_conditions.htm. Attention is drawn to the limitation of liability, indemnification and jurisdiction issues defined therein. Any holder of this document is advised that information contained herein is solely limited to visual examination of the safely and readily accessible portions of the consignment and reflects the Company's findings at the time of its intervention only and within the limits of Client's instructions, if any. The Company's sole responsibility is to its Client and this document does not exonerate parties to a transaction from exercising all their rights and obligations under the transaction documents. Any unauthorized alteration, forgery or falsification of the content or appearance of this document is unlawful and offenders may be prosecuted to the fullest extent of the law.

Attention: To check the authenticity of testing /inspection report & certificate, please contact us at telephone: (86-755)83071443, or email: CN.Doccheck@sgs.com

Page No.: 2 of 10



Part A: General Information

Section 1: Company Overview

1.1 Legal Validity			
Does the company have a valid business license?	<input checked="" type="checkbox"/> Yes <input type="checkbox"/> No <input type="checkbox"/> Others	Valid Date	No limited date
Year of established	03-Auguest-2007	Registration Number	321284000051511
Registered address	Meiwang Village, Zhangdian Town, Jiangyan, Taizhou, Jiangsu, China		
Actual address	Meiwang Village, Zhangdian Town, Jiangyan, Taizhou, Jiangsu, China		
Is the annual review done by local authority (Industrial & Commercial Bureau)?	The business license was reviewed in year 2009.		
Registered capital	RMB 100,000		
Name of legal representative	Mr. Xinming Hu		
Business scope	Special item: none Normal item: Processing, manufacturing and sales zip lock bag, plastic bag. Sales own products and relevant import & export business (except the forbidden project by government).		
1.2 Basic Information			
Contact person	Mr. Mark Hu	Email	huxinming@gmail.com
Phone number	0086-523-88559686	Fax number	0086-523-88559936
URL/Web address	www.tzjcs.com		
Company type	<input type="checkbox"/> Manufacturer <input type="checkbox"/> Foreign trader <input checked="" type="checkbox"/> Combined		
Type of ownership	<input type="checkbox"/> Limited Company <input type="checkbox"/> Public Company <input type="checkbox"/> Joint Venture <input type="checkbox"/> State-Owned <input checked="" type="checkbox"/> Private Owner <input type="checkbox"/> Others		
Subsidiary factory	No subsidiary factory		
Products manufactured / sold scope	Plastic Bag, Zip Lock Bag		
1.3 Company Building Information			
According to:			
<input type="checkbox"/> Land certificate <input type="checkbox"/> Real estate certificate			
<input checked="" type="checkbox"/> Lease agreement <input type="checkbox"/> Supplier claimed			
The land size is: around <u>1,000 square meters</u>			

This document is issued by the Company under its General Conditions of Service accessible at http://www.sgs.com/terms_and_conditions.htm. Attention is drawn to the limitation of liability, indemnification and jurisdiction issues defined therein. Any holder of this document is advised that information contained herein is solely limited to visual examination of the safely and readily accessible portions of the consignment and reflects the Company's findings at the time of its intervention only and within the limits of Client's instructions, if any. The Company's sole responsibility is to its Client and this document does not exonerate parties to a transaction from exercising all their rights and obligations under the transaction documents. Any unauthorized alteration, forgery or falsification of the content or appearance of this document is unlawful and offenders may be prosecuted to the fullest extent of the law.

Attention: To check the authenticity of testing /inspection report & certificate, please contact us at telephone: (86-755)83071443, or email: CN.Doccheck@sgs.com

Page No.: 3 of 10



Section 2: Human Resources

2.1 Company Chart

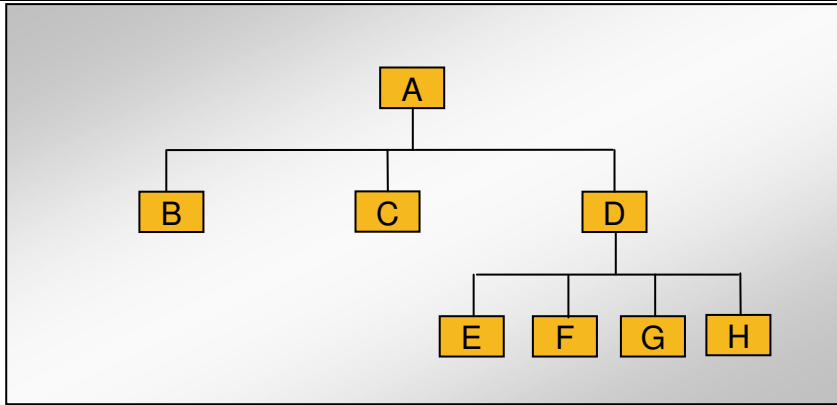

2.2 Explanation of Code and Employee Details

Code	Department	Number of employees
A	General Manager	1
B	Sales Department	2
C	Financial Department	1
D	Production Department	1
E	Technology Department	2
F	Quality Control Department	2
G	Workshop	17
H	Warehouse	4
Number in total:		30

2.3 Key Staff

Title	Full name	Education	Working experience for this trade / total experience
General Manager	Mr. Mark Hu	College level education	4 years / 10 years
Sales Manager	Ms. Cherry Hang	Junior college level education	3 years / 3 years
Foreign trade staff	Ms. Wendy Lee	Bachelor's degree	1 years / 1 years

Remark: Above all information was based on company representative claimed.

This document is issued by the Company under its General Conditions of Service accessible at http://www.sgs.com/terms_and_conditions.htm. Attention is drawn to the limitation of liability, indemnification and jurisdiction issues defined therein. Any holder of this document is advised that information contained herein is solely limited to visual examination of the safely and readily accessible portions of the consignment and reflects the Company's findings at the time of its intervention only and within the limits of Client's instructions, if any. The Company's sole responsibility is to its Client and this document does not exonerate parties to a transaction from exercising all their rights and obligations under the transaction documents. Any unauthorized alteration, forgery or falsification of the content or appearance of this document is unlawful and offenders may be prosecuted to the fullest extent of the law.

Attention: To check the authenticity of testing /inspection report & certificate, please contact us at telephone: (86-755)83071443, or email: CN.Doccheck@sgs.com



Part B: Foreign Trade Capacity

Section 1: Export Overall Situation

1.1 Export Overall Situation	
Does the company have a valid export license?	<input checked="" type="checkbox"/> Yes <input type="checkbox"/> No
The export license registration No.?	No. 320664914876
The number of foreign trading staff with relevant trading experience.	<input checked="" type="checkbox"/> within 1 year 1 staff <input checked="" type="checkbox"/> 2-5 years 1 staff <input type="checkbox"/> 5-10 years staff <input type="checkbox"/> over 10 years staff Total 2 staff
The language freely used by foreign trade staff	<input checked="" type="checkbox"/> English <input type="checkbox"/> others
Previous year annual revenue.	The company didn't provide relevant details to review due to commercial secret.
Previous year annual export revenue.	The company didn't provide relevant details to review due to commercial secret.
Estimated export revenue for this year.	The company representative claimed the estimated export annual revenue was around RMB 7,000,000 in this year.
Overseas agent	No overseas agency
Nearest port	Shanghai Port
Acceptable quotation	<input checked="" type="checkbox"/> FOB(Main) <input checked="" type="checkbox"/> CIF
Acceptable payment type	<input checked="" type="checkbox"/> LC(Main) <input checked="" type="checkbox"/> T/T
What is the company's projected average lead time from PO confirmation to production EX works delivery?	Based on interview with general manager; the average lead time was 10~20 workdays from PO confirmation to EX works delivery.

Section 2: Export Business Capacity

2.1 Market Distribution (please list top three areas)		
Market	Main Product	% of Total Business Volume (last year)
Russia	Zip Lock Bag	60%
Europe	Zip Lock Bag	10%
Middle east	Zip Lock Bag	10%

Remark: Above all information was based on company representative claimed.

This document is issued by the Company under its General Conditions of Service accessible at http://www.sgs.com/terms_and_conditions.htm. Attention is drawn to the limitation of liability, indemnification and jurisdiction issues defined therein. Any holder of this document is advised that information contained hereon is solely limited to visual examination of the safely and readily accessible portions of the consignment and reflects the Company's findings at the time of its intervention only and within the limits of Client's instructions, if any. The Company's sole responsibility is to its Client and this document does not exonerate parties to a transaction from exercising all their rights and obligations under the transaction documents. Any unauthorized alteration, forgery or falsification of the content or appearance of this document is unlawful and offenders may be prosecuted to the fullest extent of the law.

Attention: To check the authenticity of testing /inspection report & certificate, please contact us at telephone: (86-755)83071443, or email: CN.Doccheck@sgs.com

Page No.: 5 of 10



Section 3: Supplier Management

3.1 Supplier Management		
Item	Content	Observations /Comments
1	Does the company establish and implement an effective suppliers' assessment procedure?	<input type="checkbox"/> Have the written procedures and followed records <input type="checkbox"/> Have the written procedures but not records <input type="checkbox"/> Have relevant records without written procedure <input checked="" type="checkbox"/> Have no written procedures or followed records. And the company representative claimed there was a long-term supplier to cooperate.
2	Does the company have an updated list of approved suppliers?	<input type="checkbox"/> The approved suppliers list was updated in _____ <input type="checkbox"/> Have the written suppliers without approved signature or date. <input type="checkbox"/> Provide the some suppliers names <input checked="" type="checkbox"/> No approved suppliers list

Section 4: After Service Capacity

4.1 After Service Capacity		
Item	Content	Observations /Comments
1	Is there a procedure to conduct random product inspection after final packaging in place?	<input type="checkbox"/> Have clear standards and written inspection records <input type="checkbox"/> No written standards but had inspection reports <input type="checkbox"/> Have the procedures but no inspection records <input type="checkbox"/> It's not necessary to carry out the inspection <input checked="" type="checkbox"/> Other: The company representative claimed all products inspection would be finished before packing.
2	Is there a clear procedure for handling customer complaints?	<input type="checkbox"/> Has the clear procedure and followed records <input type="checkbox"/> Has the procedure but no written records. <input checked="" type="checkbox"/> No written procedures or records. And the company representative claimed all overseas complaints would be received by foreign trade staffs, and then handled & controlled by general manager.
3	Can the finished/packaged product be traced by lot identification to the appropriate raw materials test reports?	<input type="checkbox"/> Have the procedures to trace the raw materials. <input checked="" type="checkbox"/> Can trace main materials <input type="checkbox"/> Can trace production date. <input type="checkbox"/> Can't trace products
4	Are corrective & preventive actions mechanism established and implemented effectively (including the suppliers/ sub-contractors control, incoming inspection, process control, final inspection and customer complaint)?	<input type="checkbox"/> Has the clear procedure and followed records <input type="checkbox"/> Has the procedure but no written records. <input checked="" type="checkbox"/> No written procedures or records. And the company representative claimed all action would be implemented directly while not maintained documented records.









This document is issued by the Company under its General Conditions of Service accessible at http://www.sgs.com/terms_and_conditions.htm. Attention is drawn to the limitation of liability, indemnification and jurisdiction issues defined therein. Any holder of this document is advised that information contained herein is solely limited to visual examination of the safely and readily accessible portions of the consignment and reflects the Company's findings at the time of its intervention only and within the limits of Client's instructions, if any. The Company's sole responsibility is to its Client and this document does not exonerate parties to a transaction from exercising all their rights and obligations under the transaction documents. Any unauthorized alteration, forgery or falsification of the content or appearance of this document is unlawful and offenders may be prosecuted to the fullest extent of the law.

Attention: To check the authenticity of testing /inspection report & certificate, please contact us at telephone: (86-755)83071443, or email: CN.Doccheck@sgs.com

Page No.: 6 of 10

Part E: Production Capacity & Quality Control

Section 1: Production Capacity

1.1 Production Workflow Chart			
	➔		➔
Materials		Blown film	➔
	➔		➔
Printing		Bagging	➔
	➔		➔
Inspection		Package	
1.2 Products Situation in Last Year(Top three Product Categories)			
Product Category	Capacity in Top Month	Average Capacity	Total in 2009
 Description: Zip lock bag	60 Ton	50 Ton	600 Ton
Remark: Above all information was based on company representative claimed.			
1.3 Main Facilities			
Picture	Facility name	Brand or Country/Region of origin	Quantity
	Blown Film Machine	Zhejiang, China	5
	Bag Making Machine	Zhejiang, China	6

This document is issued by the Company under its General Conditions of Service accessible at http://www.sgs.com/terms_and_conditions.htm. Attention is drawn to the limitation of liability, indemnification and jurisdiction issues defined therein. Any holder of this document is advised that information contained herein is solely limited to visual examination of the safely and readily accessible portions of the consignment and reflects the Company's findings at the time of its intervention only and within the limits of Client's instructions, if any. The Company's sole responsibility is to its Client and this document does not exonerate parties to a transaction from exercising all their rights and obligations under the transaction documents. Any unauthorized alteration, forgery or falsification of the content or appearance of this document is unlawful and offenders may be prosecuted to the fullest extent of the law.

Attention: To check the authenticity of testing /inspection report & certificate, please contact us at telephone: (86-755)83071443, or email: CN.Doccheck@sgs.com



Section 2: Production Process Control

2.1 Production Process Control		
Item	Content	Observations /Comments
1	Are the environmental conditions, such as tidiness and cleanliness being controlled and suitable for the operation performed?	<input type="checkbox"/> Very tidy <input checked="" type="checkbox"/> Normal <input type="checkbox"/> Need to improve <input type="checkbox"/> Very poor
2	Are the following items /documents provided at appropriate location and under control when necessary?	<input checked="" type="checkbox"/> Work Instructions /procedures <input type="checkbox"/> Workmanship standard /acceptance <input type="checkbox"/> Golden sample /Approval sample <input type="checkbox"/> Product picture <input type="checkbox"/> Verbal by workshop director
3	Are written instructions available for incoming material inspections /testing? Is the relevant record maintained?	<input type="checkbox"/> Has instructions and uniformly followed <input type="checkbox"/> Has instruction but no written records <input checked="" type="checkbox"/> Materials checked by storage staff according pass paper or test report which provided by supplier
4	Are written inspections /testing instructions available for finished products? Is the relevant record maintained?	<input type="checkbox"/> Have instructions and uniformly followed <input type="checkbox"/> Have instruction but no written records <input type="checkbox"/> Check the products by packing staff <input checked="" type="checkbox"/> Refer to relevant records; auditor noted visual inspection would be carried according working instruction and function inspection main relate strength would be carried according inspector's experience
5	What type of inspection is used for finished products?	<input checked="" type="checkbox"/> Random inspection carried out by IPQC <input type="checkbox"/> 100% inspection <input type="checkbox"/> Visual inspection <input type="checkbox"/> Function inspection
6	Are non-conforming units clearly marked/ segregated to prevent accidental dispatch?	<input type="checkbox"/> Marked and segregated <input checked="" type="checkbox"/> Segregated but not marked clearly <input type="checkbox"/> No found in site
7	How are the non-conforming units handled?	<input type="checkbox"/> Repaired and re-inspection <input checked="" type="checkbox"/> Picked out <input type="checkbox"/> Used under control <input type="checkbox"/> Others

Section 3: Company Development / Expansion Plans

3.1 Company Development / Expansion Plans		
Item	Company Development Action(s)	Timeframe
1	Continue to invest in B2B web site.	2010
2	Strengthen to develop foreign trade business.	2010

This document is issued by the Company under its General Conditions of Service accessible at http://www.sgs.com/terms_and_conditions.htm. Attention is drawn to the limitation of liability, indemnification and jurisdiction issues defined therein. Any holder of this document is advised that information contained herein is solely limited to visual examination of the safely and readily accessible portions of the consignment and reflects the Company's findings at the time of its intervention only and within the limits of Client's instructions, if any. The Company's sole responsibility is to its Client and this document does not exonerate parties to a transaction from exercising all their rights and obligations under the transaction documents. Any unauthorized alteration, forgery or falsification of the content or appearance of this document is unlawful and offenders may be prosecuted to the fullest extent of the law.

Attention: To check the authenticity of testing /inspection report & certificate, please contact us at telephone: (86-755)83071443, or email: CN.Doccheck@sgs.com

Page No.: 8 of 10

Part H: Photos

Section 1: Photos of Documents

1.1 Photos of Documents

<p>Description: Business License</p>	<p>Description: Tax License</p>
<p>Description: Export License</p>	<p>Description: Lease Contract</p>

This document is issued by the Company under its General Conditions of Service accessible at http://www.sgs.com/terms_and_conditions.htm. Attention is drawn to the limitation of liability, indemnification and jurisdiction issues defined therein. Any holder of this document is advised that information contained herein is solely limited to visual examination of the safely and readily accessible portions of the consignment and reflects the Company's findings at the time of its intervention only and within the limits of Client's instructions, if any. The Company's sole responsibility is to its Client and this document does not exonerate parties to a transaction from exercising all their rights and obligations under the transaction documents. Any unauthorized alteration, forgery or falsification of the content or appearance of this document is unlawful and offenders may be prosecuted to the fullest extent of the law.

Attention: To check the authenticity of testing /inspection report & certificate, please contact us at telephone: (86-755)83071443, or email: CN.Doccheck@sgs.com

Section 2: Photos of Company

2.1 Photos of Company and Product Sample	
<p>Description: Company Gate</p> 	<p>Description: Office Building</p> 
<p>Description: Office</p> 	<p>Description: Process Line</p> 
<p>Description: Packing</p> 	<p>Description: Product Sample</p> 

-- End of the Report --

This document is issued by the Company under its General Conditions of Service accessible at http://www.sgs.com/terms_and_conditions.htm. Attention is drawn to the limitation of liability, indemnification and jurisdiction issues defined therein. Any holder of this document is advised that information contained hereon is solely limited to visual examination of the safely and readily accessible portions of the consignment and reflects the Company's findings at the time of its intervention only and within the limits of Client's instructions, if any. The Company's sole responsibility is to its Client and this document does not exonerate parties to a transaction from exercising all their rights and obligations under the transaction documents. Any unauthorized alteration, forgery or falsification of the content or appearance of this document is unlawful and offenders may be prosecuted to the fullest extent of the law.

Attention: To check the authenticity of testing /inspection report & certificate, please contact us at telephone: (86-755)83071443, or email: CN.Doccheck@sgs.com